

An Improvement Approach for a Short Wave Absorption Type Water-in-oil Sensor

Liu Haijiang*

University of Science and Technology Liaoning, 114051, China

Abstract: Water-in-oil monitoring has been widely applied in the petroleum, chemical and shipping industries as a method of short wave absorption. However, due to enhancements in equipment precision and efficiency, more demands are being made on oil products. In order to meet these needs, it is insufficient to merely rely on improving the design of secondary instruments. Based on a wide range of practices, this paper proposes effective modifications to the transmitter itself in order to solve problems in equipment debugging and operation. These modifications include: improving the zeroing circuit to achieve an acceptable range of auto-zeroing and enhance the debugging efficiency; altering the true and false load method to achieve a differential calculation in a real sense; and changing the instrument structure to realize the integrated design and solve the problem of common-mode interference in the transmission of original signals.

Keywords: Auto-zeroing, common-mode interference, short wave absorption, true and false load.

1. INTRODUCTION

There are many approaches that can be used in order to test the water content in oil and these various methods are based on different classification standards. For example, with regard to the test location, there is online testing and laboratory testing. Furthermore, regarding the test method, there are approaches based on physical methods, such as the gas chromatography method, the humidity percentage method, the manometer measurement method and the conductivity method, and methods based on chemical reactions as the Karl Fischer method. These methods all have advantages and disadvantages [1]. The frequency range of electromagnetic short-waves is 3 to 30 MHz. A liquid medium virtually absorbs short-waves when they are passing through it. When electromagnetic waves with the same frequency pass through different media, the amount of short-wave energy they absorb differs. The shortwave energy absorbed by a medium is calculated by using the Beer-Lambert law [2].

$$I = I_0 e^{-\mu c l} \quad (1)$$

Equation (1) is derived as follows:

$$I_0 = I e^{\mu c l} \quad (2)$$

where I is the penetration energy;

I_0 is the incidence energy;

μ is the absorption coefficient;

c is the concentration of the medium;

l is the thickness of the medium.

For mixed media, there is:

$$I_0 = I e^{(\mu_1 c_1 l + \mu_2 c_2 l + \dots)} = I e^{\mu_1 c_1 l} I e^{\mu_2 c_2 l} \dots \quad (3)$$

In Equation (3), $\mu_1 c_1 l$ and $\mu_2 c_2 l$ respectively represent the absorption coefficient and the concentration and thickness of media of two different substances. When the test equipment is used to test the water content of oil, the two substances are water and oil. The value of μ_2 , namely the absorption coefficient when oil absorbs the electromagnetic wave of 4 MHz emitted by the shortwave transmitter, is quite small, approximately equal to zero. Therefore, Formula (3) can be written as:

$$I_0 = I e^{\mu_1 c_1 l} \quad (4)$$

When the size of a sensor is fixed and the environment is fixed with regard to the completion of its installation on a tank or a pipeline, it can be seen in Equation (4) that the transmission power only varies with the change of water content, namely the change of I_0 . The operating principle of the shortwave transmitter design based on this is shown in Fig. (1).

In practice, the shortwave absorption method has the advantages of stability, a strong anti-jamming capability, and the availability of continuous online testing. It is widely used in the petroleum industry for testing the water content of oil (water-in-oil) and monitoring the interface of water and oil in oil tanks and the water content of oil in ships on the surface of, or under, water. However, as demands for equipment to have a higher oil quality increase, it becomes necessary to improve the performance parameters of the test equipment. Products are also being improved from type I and II to type III. Moreover, the shortwave transmitter has not been changed before. It is obvious that if only the A/D conversion accuracy of the secondary instrument circuit and the computing power of the microprocessor are improved these changes in themselves will not lead to a good design specification. For example: the display accuracy is improved, but the stability declines; the accuracy is improved, but the transmitter zeroing becomes difficult; and sometimes it takes 30 minutes

*Address correspondence to this author at the University of Science and Technology Liaoning, 114051, China; E-mail: liuhaijiang@ustln.edu.cn

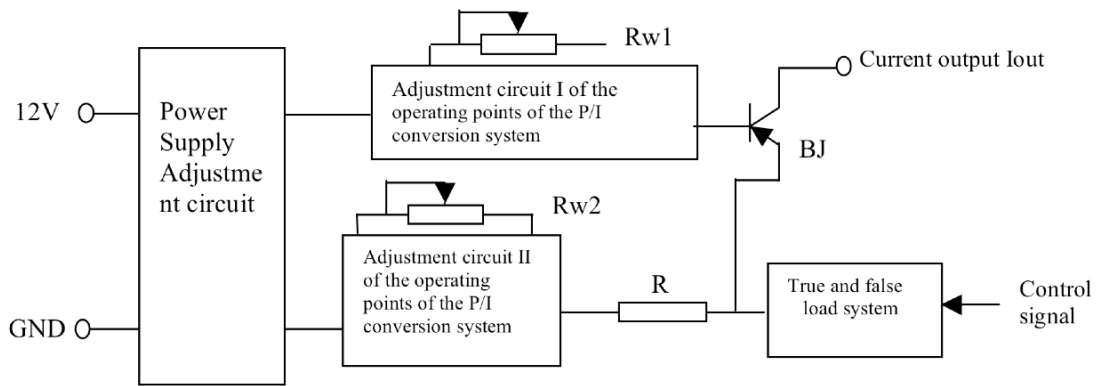

Fig. (1). The operating principle of the transmitter.

or more to complete the marking of the equipment's zero point calibration. Having considered these problems, this paper aims to improve the zeroing method of shortwave transmitters, the working method of the true and false load and the overall design.

2. IMPROVEMENTS TO THE ZEROING METHOD

2.1. The Improvement Approach

2.1.1. Manual Zeroing

The zeroing of the original transmitter is carried out by using an analog circuit, respectively adjusting the resistance of potentiometers R_{w1} and R_{w2} and altering the quiescent operating point of the BJ transistor's base and emitter. When the emitter is immersed in pure oil, the value of the true and false load current that is converted through P/I is fixed, for example the display of 0.01 in the SHY I and II meters. It is not too difficult to zero the original meter with low measurement accuracy. However, when designing SHY III and IV, as the measurement accuracy of the meter improves, zeroing becomes more difficult if the aim is to display the reading of pure oil as 0.001 or 0.0001. This is because it is time-consuming and more onerous for the operator. Furthermore, the zeroing needs to be conducted both when the equipment is being accepted and after installation. As the device components begin to age, the zero point may drift, which affects the measurement accuracy. Therefore, it is necessary to improve the design of the part responsible for zeroing in the circuit. Based on this working principle, it is not feasible to simply apply the zeroing method of "peeling" [3].

2.1.2. Auto-zeroing

The paper proposes improvement approaches based on the original circuit in order to achieve auto-zeroing. The circuit is shown in Fig. (2).

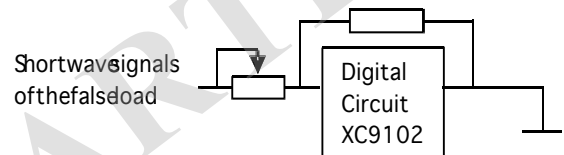

Fig. (2). The digital potentiometer circuit.

The resistance of the XC9102 ranges from 10 to 1 kOhms. It is divided into 100 steps, with a step size of 10 Ohms. When tested it was found that the step size was still too large, and failed to meet the zeroing requirements of a high accuracy transmitter. Therefore, a resistor of 1 kOhms was paralleled at the both ends of the digital potentiometer in order to shorten its step size and meet the zeroing requirements. However, this also makes the change of resistance a non-linear adjustment, and not a linear adjustment; this is shown in Fig. (3).

As it has to meet the error requirements of zeroing, auto-zeroing can be accomplished through software programming and the calculation formula is as Formula (5) below:

$$\Delta I_{out} = I_{out \text{ True}} - I_{out \text{ False}}, \tag{5}$$

in the formula, ΔI_{out} is the allowable error of zeroing. In oil with a water content of 0.0001, the value of the measurement instrument is ± 0.0005 .

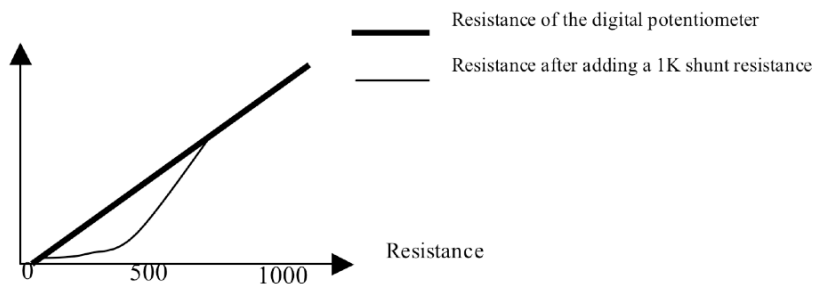

Fig. (3). The changes in the resistance of digital potentiometer.

Table 1. The data sheet of auto-zeroing testing.

First	Second	Third	Forth	Fifth
0.0003	0.0005	0.0001	0.0004	0.0001

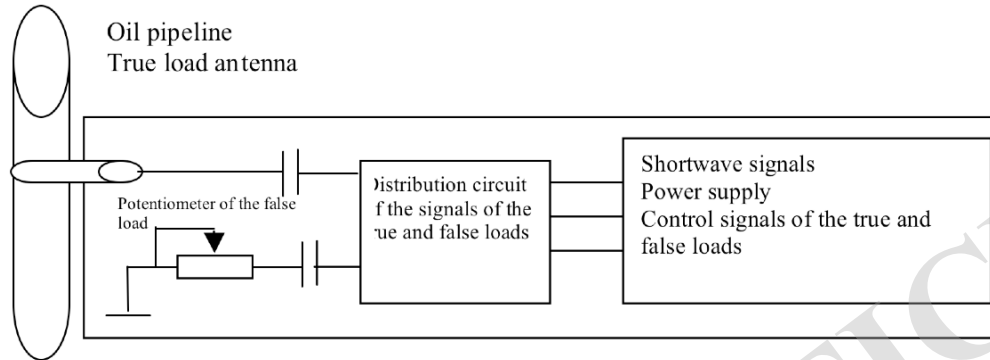

Fig. (4). The original shortwave transmitter (composition and structure).

2.2. The Test Data

When manual zeroing, after a long zeroing operation, it is always possible to obtain a display of 0.0001 zero point on the second meter in pure oil. However, the auto-zeroing cannot guarantee that every auto-zeroing operation will display a value of 0.0001. The values achieved after zeroing has been repeated five times are shown in Table 1.

The test standard requires that the value can't be 0.0001 when marking the zero point calibration, therefore if the value is less than 0.0001 when conducting zeroing and calculating the procedures of a microprocessor, a zero point value greater than 0.0001 should be taken. The five tests above basically meet these requirements. With this improvement, even in the field, the zero adjustment of the instrument can be fulfilled by the zeroing button on the condition that the oil is pure. This was impossible to conveniently implement in previous instruments. Therefore this proposal has solved the long-term problem of zero drift of working instruments and enhanced their measurement accuracy.

3. IMPROVEMENTS TO THE WORKING METHOD OF TRUE AND FALSE LOAD

3.1. The Improvement Approaches

Due to the impact of sources of interference, such as the temperature and surrounding environment, temperature drift and zero drift may occur in electronic components [4]. Over time, a wide range of temperature changes and the discreteness variations of electronic components will intensify the temperature drift and zero drift, thereby reducing the signal to noise ratio and ultimately affecting the measurement results. In order to solve this problem, the original transmitter applied the true and false double shortwave signals for transmission and provided true and false load currents for the secondary instrument. The signal of the difference between the former two signals is taken as the valid signal in order to guarantee that the measurement results are not affected by

temperature drift, zero drift and various other disturbances and to stabilize the measurement data. In the case of a requirement for less precision, this is a good solution for common-mode interference in the signal transmission. However, when the accuracy is improved, this approach no longer meets these requirements. Having analyzed the working principle and hardware components, the authors found that the reasons for this are that the true load in the instrument uses a 4 MHz transmitting antenna (a metal rod), and the signal processing section of the false load is the same as that of the true load; yet its transmitting antenna has adopted a precision potentiometer of 5 kOhms. One of the antennae is installed on the tested oil pipeline (box), while the other is welded to the circuit board of the transmitter. Therefore the common-mode interference cannot be completely offset. In the actual measuring process, the currents of the true load and the false load cannot "follow-up" (the two currents rise and fall simultaneously), resulting in significant errors in the measurement data. The hardware of the original shortwave signal transmitter is shown in Fig. (4).

The improvement is achieved *via* two aspects. Firstly, the false load uses the same shortwave transmitting antenna (metal rod) as that of the true load. Then, it is placed in a sealed container filled with the same anhydrous pure oil as the oil being tested. Its true load transmitting antenna is still installed at exactly the original position. Providing the antennae are the same size and placed in the same working environment, meaning they are affected by the same environmental temperature, temperature changes and electromagnetic interference, the ideal situation will be that the current difference between them is zero. If Equation (4) is used, only when the water content of the tested oil is changed, the current that is tested through the true load circuit will change, reflecting the water content in the oil. At the same time, the true and false load method can also adequately offset the common-mode interference, guaranteeing stable and reliable measurement values and improving the stability of the measurement.

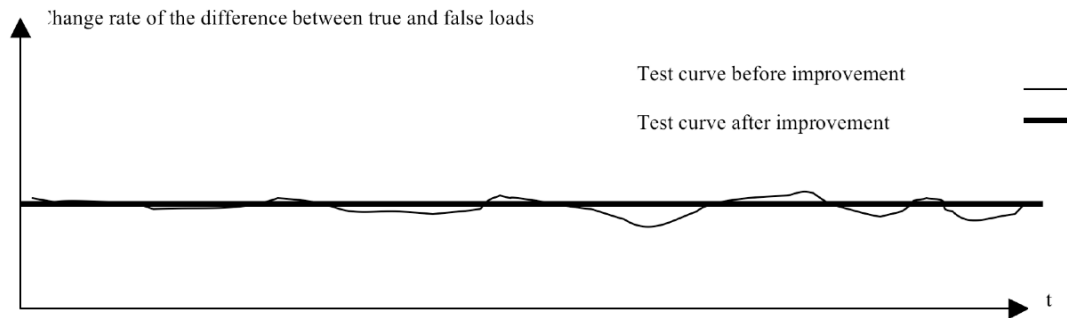

Fig. (5). The change before and after the improvement with a constant water content.

3.2. The Test Data

Having improved the transmitter by using these new approaches, a lengthy testing process took place under the condition that the water content of the tested oil was constant. The data obtained from the test was compared with the original testing data, as shown in Fig. (5).

Over a long period of testing, it was found that this change was successful and therefore a good solution to the drift problem of testing data when using test equipment with a high precision over time.

4. THE INTEGRATION DESIGN

In the original test equipment, the transmitter and secondary instrument are separated in the design and 6-core cables are used for the signal transmission between them. When using the test equipment, it was found that if the cables are affected by electromagnetic and other signal interference, the stability of the tested data of the water content in oil will also be affected. In the new design, an integration design is applied and the transmission cables using an analog signal are abandoned; therefore the anti-jamming capability of the instrument is strengthened. It will use digital serial data transmission, such as RS-485, for data transmission.

5. CONCLUSION

As society continues to improve, the precision of devices becomes increasingly sophisticated, and consequently the need for high quality oil is also increasing. Subsequently, demands for the greater accuracy of test equipment are also

growing. In oil of a high purity, the change of water content in the oil, both on the surface of, and under, the water is continuously and precisely tested by the water cut meter in the operating equipment. The changes proposed to the equipment in this paper also mean that it can withstand the challenges of high temperature, humidity, electromagnetic interference and other harsh environments. The result is that it operates sufficiently and works in a stable manner. This proves that the shortwave absorption transmitter and the water cut meter are feasible solutions to everyday problems. As the technology for oil products continues to be enhanced, these improvements will play an increasingly important role in the future.

CONFLICT OF INTEREST

The authors confirm that this article content has no conflict of interest.

ACKNOWLEDGEMENTS

Declared none.

REFERENCES

- [1] Zhang Wan, "Analysis on Test Methods of Water Content in Oil," *Engine and Accessories*, 2, 2100, pp. 19-20.
- [2] Y. Yu, "Analysis of Water Content in Sample Oil with Shortwave Absorption Method," *Surface Engineering of Oil and Gas Fields*, vol.6, pp. 102-103, 2010.
- [3] H. Liu, Research on Load Monitoring System, *Instrumentation Technology*, Beijing, vol.1, pp. 30-31, 2003.
- [4] H. Liu, "Analog Electronic Technology," *Railway Press*, Beijing, pp. 54-57, 2011.

Received: September 16, 2014

Revised: December 23, 2014

Accepted: December 31, 2014

© Liu Haijiang; Licensee *Bentham Open*.

This is an open access article licensed under the terms of the Creative Commons Attribution Non-Commercial License (<http://creativecommons.org/licenses/by-nc/3.0/>) which permits unrestricted, non-commercial use, distribution and reproduction in any medium, provided the work is properly cited.