

# Design of a Video Data Sampling and Transmission System Based on Wireless Mesh Network

Liu-qing Yang<sup>1,\*</sup> and Guo'an Zhang<sup>2</sup>

<sup>1</sup>Computer Department of Fuzhou Polytechnic, Fuzhou, Fujian, China

<sup>2</sup>Information Science and Engineering School of FJUT, Fuzhou, Fujian, China

**Abstract:** A video data sampling and transmission system is designed for video monitoring based on wireless mesh network. Discussion is made on the use of standards, working frequency, network infrastructure, coverage solutions, link budget, frequency planning, power supply, supporting transmission and AC design. Overall solution on wireless Mesh network digital video system is proposed and it is applied to practical wireless network video monitoring system, and good results are achieved through practical application.

**Keywords:** Video monitoring, frequency planning, data sampling, Mesh, link.

## 1. INTRODUCTION

Since safety requirements have become more and more important, digital video surveillance networks have been widely used in various industries. The use of wireless Mesh network technology can quickly build video surveillance network to meet the requirements of economic and social development. In a mountainous area or terrain, scattered population living requires good coverage, but cable distribution network results in high cost. So it is urgently needed for urban fringe or rural areas, especially the development of wireless access coverage.

## 2. DESIGN AND CONSTRUCTION OF A WIRELESS DATA SAMPLING AND TRANSMISSION SYSTEM

### 2.1. Design Standards and Principles

1) Using standard

① Wi-Fi 802.11n/WAPI:

Thin AP equipments which support Wi-Fi/WAPI standard are used for networking.

② 802.11n:

Equipments which meet the 802.11n standard are mainly used for networking. 802.11n selecting factors include hot spots type, design capacity, and network development [1]. For hot spots in high demand of network capacity, 802.11n devices should be used directly for construction.

Working frequency and principles of application

① Working frequency [2]:

WLAN 802.11n work in the 2.4GHz band, the frequency ranges from 2.400 to 2.4835GHz. Total bandwidth of 83.5M is divided into 13 subchannels, bandwidth of each subchannel 22MHz; among which three channels have no interference. Generally, the proposed frequency points are 1,6,11. Subchannel allocation is shown in Fig. (1).

Frequency configuration for each channel is shown in Table 1.

For WLAN 802.11n equipments working in 5.8GHz band, the frequency ranges from 5.725GHz to 5.850GHz, a total bandwidth of 125MHz is divided into five channels, bandwidth of each channel is 20MHz. These non-overlapping channels can all be used. Sub-channel assignment is shown in Fig. (2) and Table 2.

② The principle of frequency applications [3]

2.4GHz band selection: There are many interferences in 2.4GHz band, such as interferences from other network operators, owners self-built network. 20M bandwidth should be adopted for networking and planning, three non-overlapping channels 1,6,11 should be selected. If independent operators are allowed to distribute network, with less interference and fewer number of AP, 40MHz or a 20M with a 40M-band can be used for networking.

5.8GHz band selection: there is relatively less interference in 5.8GHz band, so two 40M with one 20M should be adopted for networking (corresponding to three frequency spots with the 2.4GHz), or five 20M-band networking (for intensive case of AP deployment). In the area with less interference or only independent distributing network operators are allowed, one or two 40M networking solutions can be used. Indoor distribution system does not support the 802.11n devices under 5.8G band, devices under 2.4G should be used. The case of independent construction, if possible, the 5.8G band should be applied to reduce interference.

\*Address correspondence to these authors at the Computer Department of Fuzhou Polytechnic, Fuzhou, Fujian, China; Tel: 1855800960; E-mail: [y.liuqing@163.com](mailto:y.liuqing@163.com)

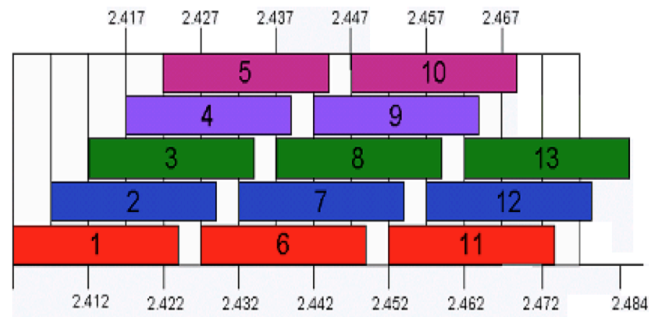

Fig. (1). 2.4GHz working frequency band allocation for subchannels.

Table 1. 4GHz frequency configuration for channels.

Channel	Central Frequency	Channel Low/ High end Frequency
1	2412MHz	2401/2423MHz
2	2417MHz	2406/2428MHz
3	2422MHz	2411/2433MHz
4	2427MHz	2416/2438MHz
5	2432MHz	2421/2443MHz
6	2437MHz	2426/2448MHz
7	2442MHz	2431/2453MHz
8	2447MHz	2436/2458MHz
9	2452MHz	2441/2463MHz
10	2457MHz	2446/2468MHz
11	2462MHz	2451/2473MHz
12	2467MHz	2456/2478MHz
13	2472MHz	2461/2483MHz

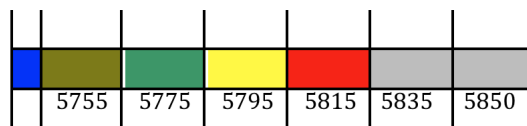

Fig. (2). 5.8GHz working frequency band allocation for subchannels.

3) AP emission power

According to specifications of China's telecommunication industry wireless LAN AP, AC equipment, AP emission power should meet following requirements:

- ① For mounted indoor 802.11n thin AP (with two spatial streams, supports dual-band 2.4G and 5.8G simultaneously), RF output equivalent isotropic radiated power  $\leq 20\text{dBm}$ ;
- ② Indoor division and combined type 802.11n thin AP (single spatial stream, supports 2.4GHz band), AP device output power  $\leq 27\text{dBm}$ , and RF output equivalent isotropic radiated power  $\leq 20\text{dBm}$ ;
- ③ Outdoor 802.11n thin AP, adjustable emission power, RF output equivalent isotropic radiated power  $\leq 27\text{dBm}$ ;

Table 2. 5.8GHz frequency configuration for channels

Channel	Central Frequency	Channel Low/ High end Frequency
149	5745 MHz	5735/5755MHz
153	5765 MHz	5755/5775MHz
157	5785 MHz	5775/5795MHz
161	5805 MHz	5795/5815MHz
165	5825 MHz	5815/5835MHz

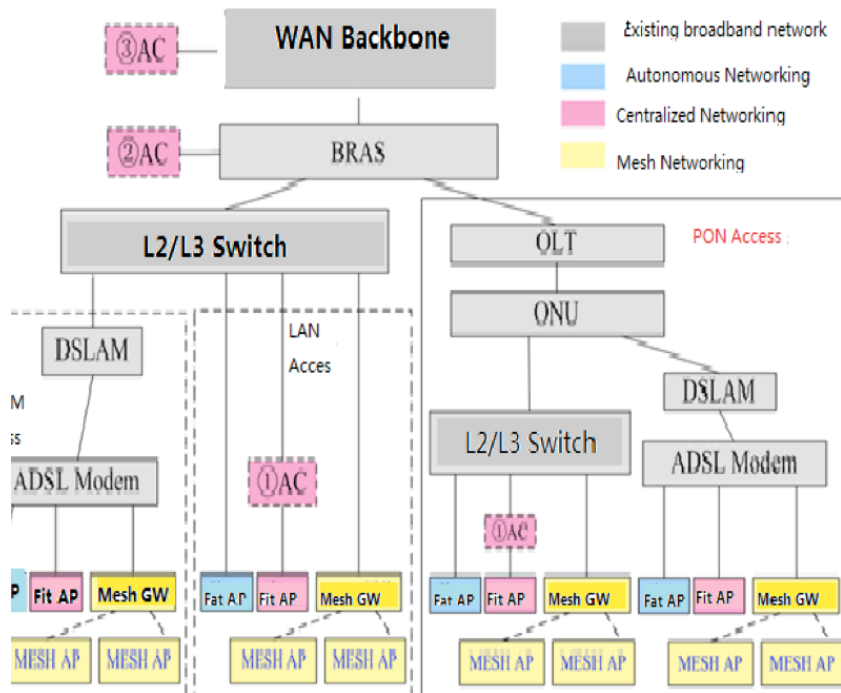

Fig. (3). WLAN network architecture based on Mesh.

④ When combined construction methods are used, antenna port power should comply with national requirements for electromagnetic radiation protection.

## 2.2. Design of Mesh Transmission System

### 1) Network architecture

Various types of AP are included in wireless access points. In wireless access points, thin AP devices should be applied to simplify installation and upgrade, and to meet the requirements of centralized management for a network. Cable connection is commonly used between AP and switch/ONU, with no more than 100 meters transmission distance, usually no more than 80 meters. When the transmission distance increases beyond the length of cable transmission, connection such as optical switches can be used. Each AP can be converged by switch/ONU. According to the number of hot spots and distribution, 1-2 levels of switch/ONU can be used. With large quantities and wide

distribution of AP, an aggregation switch should be used to converge each access switches. With small amount of AP and concentrating distribution, one level of switch/ONU is enough. In hotspots with PON access conditions, part or all of the switches can be replaced by ONU. With higher level of security needs, the hotspot aggregation switches should get one backup (as the aggregation switch 2 in Fig. 3), for redundant aggregation nodes or in the uplink and downlink and to improve the reliability of the network. If there is no condition for a wired connection between switch and AP/ONU, a wireless 5.8GHz bridge can be used. Wireless bridges should follow some principles: 2.4GHz +5.8 GHz dual-band AP should be used, where 2.4GHz frequency covers user, 5.8GHz frequency is used as wireless backhaul.

### 2) Coverage solutions

#### ① AP independent installed

AP directly covers indoor target region through a pair of antenna;

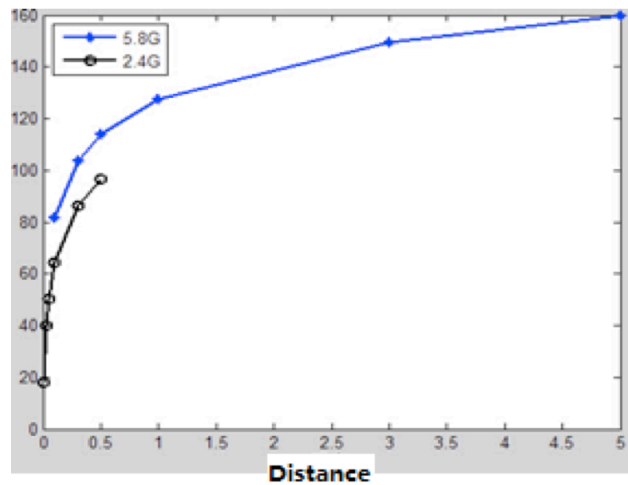

**Fig. (4).** Propagation loss of electromagnetic waves in free space path.

Frequency interval and environment should be noted in the search of AP placement points;

The antenna should be installed at the location where target region can well be covered. If special needs to beautify the environment are considered, an external antenna should be installed on a concealed position with little impact on covering effect, or the use of landscaping antenna; the antenna must be placed outside of metal ceilings;

Antenna can either be mounted directly on the antenna port of AP, or be connected via coaxial cable. To avoid unnecessary loss, the distance between AP and its antenna should be shortened.

#### ② AP combiner indoor distributed antenna system

By the use of building, the existing or new distribution system should be moved to combine WLAN signal;

Indoor distributing system components are required to support 2.4-2.5GHz frequency band;

Distance between indoor division system antennas must meet the requirements of WLAN coverage;

According to AP output power, under the premises to meet coverage and interference isolation requirements, number of combined nodes should be reduced;

Distribution system can be combined with AP direct coverage to cover the target area. AP direct coverage is used to solve capacity design.

#### ③ AP access to a small distribution system

a) On hot spot with no indoor distribution system, where target coverage area is a plurality of continuous separating space, and the traffic is not big, an AP is connected to multiple antennas to cover the target area, in order to achieve a small distributing system in local area;

b) To select the power of AP according to the actual need, power is allocated to each antenna by power splitter / coupler, output power on each antenna port ranges from 10 to 15dBm, shall not exceed 20dBm.

#### ④ AP outdoor coverage

a) Outdoor AP is used to cover indoor target area;

b) Taking into account penetration loss of building, when the thickness of the building does not meet the requirements of loss, several AP should be used to cover from multiple directions;

c) Distance from antenna to target buildings should be within 100m;

d) According to height to hang antenna and horizontal / vertical lobe angle, ability of an antenna horizontal and vertical coverage can be estimated, width and height of building should be within the coverage range of the antenna, and declination of the antenna should be noted.

#### ⑤ Mesh networking

Mesh networking is one kind of network architecture based on multi-hop routing, where Root AP and Mesh AP are jointly used to cover a contiguous area. Among them:

a) Root AP: refers to AP connected to the upper level network via a wired way. Root AP enables users to access an AP aggregation. In placement of Root AP, transport and electricity are needed to provide;

b) Mesh AP: This refers to AP backhauled signal to the Root AP by wireless way, where local user access is achieved. In placement of Mesh AP, only electricity is required.

#### 3) Link budget

##### ① Outdoor propagation model

Free-space propagation model can be used in an open space, the propagation loss of electromagnetic waves in a free space path is consistent with:

$$L_0(dB) = 92.4 + 20\lg(d) + 20\lg(f) \quad (1)$$

Where:  $L_0$ : free space loss (unit: dB);  $D$ : transmission distance (unit: Km);  $F$ : working frequency (unit: GHz). Respectively taking:  $d = 0.1$  to  $0.5\text{Km}$ ,  $1$  to  $5\text{Km}$ ;  $f = 5.8\text{GHz}$ , and  $d = 0.01$  to  $0.05\text{Km}$ ,  $0.1$  to  $0.5\text{Km}$ ,  $f = 2.45\text{GHz}$ ; calculation results are shown in Fig. (4).

Table 3. Typical attenuation factor.

Environment	n
Full open environment	2.0~2.5
Semi-open environment	2.5~3.0
Relatively closed environment	3.0~3.5

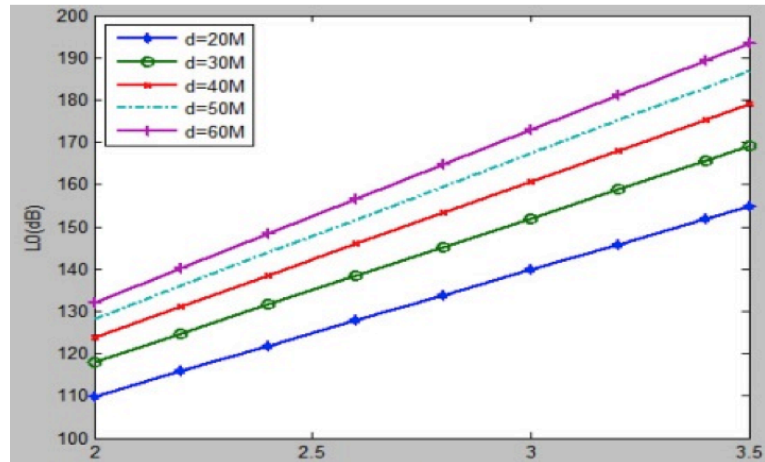

Fig. (5). Indoor radio propagation model under attenuation factor n.

② Indoor attenuation factor [4]

In indoor environment, an attenuation factor model can be selected for indoor radio propagation model, its expression is:

$$PL(d)[dB] = PL(d_0) + 10n \lg\left(\frac{d}{d_0}\right) + SF \tag{2}$$

Wherein:  $PL(d_0) = 20 \lg(4\pi d_0 / \lambda)$ , and generally take  $d_0 = 1m$ , when the frequency is 2.45 GHz, its value is 40 dB; n: attenuation factor, is associated with the propagation environment, can be seen in Table 3; SF: additional attenuation factor, refers to the additional loss caused by floor, partitions, walls etc.

Theoretical calculation of coverage effect: If the maximum transmission distance in engineering design ranges from 20 to 60m, n is from 2 to 3.5, results are shown in Fig. (5).

As a model of additional attenuation factor with zero mean logarithmic normal distribution (in dB Gaussian distribution), that is, [1]

$$p_{SF}(x) = \frac{1}{\sqrt{2\pi\sigma_{SF}}} \exp\left(-\frac{x^2}{2\sigma_{SF}^2}\right) \tag{3}$$

4) Frequency planning [5]

WLAN frequency planning should follow the following principles:

① The location of a signal source will have a great impact on the effect of signal coverage and interference, so it should be reasonably placed to make it conducive to signal coverage and minimal interference with each other based on the actual building, partitions circumstances.

② On outdoor and indoor overall open area, cellular layout should be used, including a uniform distribution of the signal in horizontal and vertical directions, the frequency multiplexing for WLAN is shown in Fig. (6):

③ The coverage area of each AP will be shown according to the distribution of users within the coverage area and design diagram, then possible blind spot region may be analyzed. Considering interference between AP, especially interference with existing AP, laying of AP should be adjusted. In addition, mutual interference of adjacent floors AP will appear, so pay special attention to consideration of the coverage area of each AP from a three-dimensional view.

④ Overlap area between AP coverage regions can ensure seamless coverage and adapt to load balancing; distance between different AP in the same channel should be controlled to reduce interference.

⑤ When AP and other mobile communication networks (such as GSM, TD-SCDMA, TD-LTE) are built on the same site, isolation between different systems should meet technical requirements.

⑥ Mounting location of AP antenna should be far away from electronic equipment, or to shield the source of interference such as microwave ovens, monitors, motors, etc. if necessary.



To improve network reliability, another AC should be used for backup.

### 3. OVERALL DESIGN OF WIRELESS NETWORK VIDEO MONITORING SYSTEM

#### 3.1. System Architecture

A wireless network video monitoring system consists of monitoring front-end, wireless network link and the monitoring center / monitoring client. When users do not need to constantly record, the monitoring center functions can be cancelled, then the system only consists of the monitoring front-end and monitoring client. As long as the front-end equipment is working, video surveillance can be done in any wireless network coverage location, not constrained by the center and the relative area. As a result, digitized video transmission system is realized in the true sense.

#### 3.2. Monitor Front End

Monitor front end consists of wireless network equipments and monitoring camera, output of the monitoring camera is a fully digital conversion, the interface of which is simple and easy to link. The camera can be a gun style machine (ordinary gun type machine, infrared integrated machine), or a ball style machine (ordinary ball machine, high speed ball machine, medium-speed ball machine, infrared integrated machine). After the camera video is captured by wireless device, it is sent to the monitoring center to establish monitoring video streams. For traditional analog cameras, network video server can access the camera's video interface. With a combination of network video server and a wireless network, the front-end video is transmitted to the monitoring center via a wireless link [7,8].

#### 3.3. Network link [9]

A wireless video professional network can be established by a single or multiple wireless network devices based on system requirements, where the wireless devices adopt standard 802.11n protocols, and 5.8GHz/2.4GHz band is used for data transmission. A wireless video network can be a structure composed of point to multipoint, multilevel relay and point to point network. For safety performance in the transmission channel, MAC address filtering and 128-bit WEP/WPA/WPA2/dual-layer isolation are used, end-user's connection with a wireless device is limited to protect the safety of video channels [10]. Multi polarized antenna design, antenna power, and wireless network management make it possible for video communication and flexible networking over more than 10 kilometers through software control.

#### 3.4. Monitoring Center and Client [11]

A monitoring center consists of one server, one monitoring PC or large-screen monitor. Software system of the server completes video forwarding from front-end video surveillance point, and video server recording. Client software on monitoring PC can connect to the server software system according to demand, get video streams from server-side forwarding. Video information is also available directly from

the front-end control point. Clients can implement video monitoring, control, alarm, record and historical retrieval.

### CONCLUSION

During overall system design, hierarchical and systematic network structure is used, and function model of different layers are strictly defined, attention to different characteristics of the configuration are paid on different layers. By reasonable analysis and practical tests, AP's actual coverage and the actual capacity is obtained and applied in software industrial campus, fishing port, highway construction projects and other security monitoring. This system achieved reasonably economic and social benefits. However, there are still some problems in system maintenance, because maintenance services of a wireless Mesh network monitoring systems is more complex than other communication systems. First of all, a wireless Mesh network is operating in an unauthorized frequency band, which has got more serious interference compared with other wireless communication system. Secondly, AP in a Wireless Mesh Network, indoor distribution systems are typically deployed under the public environment where no reliable power supply and no physical protection is available. All of these factors have brought greater uncertainty to the running quality of a wireless Mesh network, increasing the difficulties of wireless Mesh network maintenance. Nevertheless, there is still an important reference value in the construction of a video surveillance system (e.g.: video surveillance on campus, production and processing sites and dangerous positions etc.). As a reference design, it is of significance for the upcoming 802.11ac WLAN standard [12].

### CONFLICT OF INTEREST

The authors confirm that this article content has no conflict of interest.

### ACKNOWLEDGEMENTS

Project is supported by Science & Technology Foundation of Fuzhou, China, (Grant No.2013-G-96), Natural Science Foundation of Fujian Province, China (Grant No.2010J05157), and Key Science and Technology Foundation of Fujian Province, China (Grant No.2014H6006).

### REFERENCES

- [1] E. Perahia, and R. Stacey, "Next Generation WLAN," Beijing: People's Posts and Telecommunications Press, vol. 9, pp. 9-13, 35-36, 2010.
- [2] F. Gao, Z. Gao, and L. Wen, "Wireless City - Carrier-grade Wi-Fi Network Construction and Operation", Beijing: People's Posts and Telecommunications Press, vol. 1, pp. 87-94, 2011.
- [3] X. Xie, "Computer Network (6<sup>th</sup> ed.)," Beijing: Electronic Industry Press, vol. 6, pp. 360-378, 2013.
- [4] Z. Wu, and X. Gao, "Improved MIMO-OFDM scheme for the next generation WLAN," *Journal of Systems Engineering and Electronics*, vol. 24, no. 1, pp. 52-59, 2012.
- [5] Z. Hu, X. Wang, and Z. Xian, "Reliable multicast in wireless mesh networks based on routing quality," *Journal on Communications*, vol. 32, no. 5, pp. 1-7, 2011.
- [6] J. Wang, "Implementation of enterprise WLAN," *Power System Communication*, vol. 31, no. 214, pp. 35-39, 2010.

- [7] D. Liang, Y. Zhang, and N. Cao, "Network video monitoring technology and intelligent application," Beijing: People's Posts and Telecommunications Press, pp. 233-260, 2013.
- [8] F. Cao, "Wireless video surveillance, security battlefield force," *Shanghai Informatization*, no. 8, pp. 35-39, 2013.
- [9] F. Li, J. Wang, and C. Chen, "Method of performance evaluation for wireless mesh network," *Application Research of Computers*, vol. 30, no. 2, pp. 551-553, 2013.
- [10] X. Li, X. Wang, and J. Shen, "Strategy & simulation of trust cluster based key management protocol for Ad hoc networks," In: *Proceeding of fourth ICCSE*, vol. 8, pp. 269-274, 2009.
- [11] S. Xi, "Detailed of intelligent network video surveillance technology and practice," Beijing: Tsinghua University Press, pp. 348-361, 2010.
- [12] IEEE P802.11ac/D2.0 Draft standard for information technology-telecommunications and information exchange between systems-Local and metropolitan area networks-Specific requirements, Part 11: Wireless LAN medium access control (MAC) and Physical Layer (PHY) specifications. Amendment 4: enhancements for very high throughput for operation in bands below 6GHz, 2012.

---

Received: May 26, 2015

Revised: July 14, 2015

Accepted: August 10, 2015

© Yang and Zhang; Licensee *Bentham Open*.

This is an open access article licensed under the terms of the (<https://creativecommons.org/licenses/by/4.0/legalcode>), which permits unrestricted, non-commercial use, distribution and reproduction in any medium, provided the work is properly cited.