

Operation Mode Analysis, Parameter Matching and Control Strategy Research for a Novel Range-Extended Electric Vehicle

Jianjun Hu^{*}, Guoqiang Zu, Ming Xie and Jia Chen

State Key Laboratory of Mechanical Transmission, Chongqing University, Chongqing, 400044, China

Abstract: In order to improve the dynamic performance and endurance mileage of vehicle, operation mode and parameter matching were analyzed and designed on a novel power transmission scheme of range-extended electric vehicle (R-EEV), and the following control strategy of the engine optimization curve was proposed. The simulation was carried out on the Matlab/Simulink software platform and the results showed that the matching parameters and the control strategy of engine were both reasonable, the dynamic performance improved and the vehicle could be operated efficiently.

Keywords: Control strategy, Operation mode, Parameter matching, Range-extended electric vehicle.

1. INTRODUCTION

As energy crisis and environmental issues such as pollution and global warming have become increasingly worse, new energy resources for automotive industry are required. As a kind of configuration between the pure electric vehicle and conventional hybrid electric vehicle, R-EEV [1] equipped with auxiliary power unit (APU) on the basis of the pure electric vehicle can guarantee the vehicle's driving range and battery durability, so that the level of the electric energy alternatives to fossil fuels can be increased.

At present, the research and development institutions have focused their work on integrated development of Range-Extender, the design of the matching parameters, vehicle operation mode and the research of control strategy. QU Xiaodong *et al.* [2] proposed a control strategy of auxiliary power unit (APU), which consists of a gasoline engine and a permanent magnet synchronous motor (PMSM), and the test results show that the control strategy proposed can meet the performance requirements of range-extended EV very well. Zhou Su *et al.* [3] proposed a fixed-point energy management strategy of the engine and matched the parameters for the core components of the powertrain in a series E-REV, and co-simulation based on AVL-Cruise/Simulink was carried out to verify the reasonableness of the matching parameters. Hao YU *et al.* [4] proposed a double-point energy management control strategy of the engine and analyzed the simulation of matching parameters with AVL-Cruise software for the E-REV. The operation mode of the E-REV was divided into four operation modes: the pure electric operation, the engine's economic area operation, the engine's high load operation and the recovery of braking energy operation. Considering the power distribution in urban cycle and high-speed road, Scott engine plug-in electric vehicle with Advisor software verified the advantages of Wankel engine in plug-in electric vehicle. Gregory L. Plett *et al.* [6] studied

the application of boron phosphate batteries on E-REV and conducted a research on the control strategy of the battery energy management. In addition, Matthew Doude, Yimin Gao *et al.* [7-9] studied the matching methods of the E-REV and conducted a simulation test by the tool of hardware-in-the-loop (HIL) such as DSPACE.

At present, the series extended range mode is mostly used in the powertrain of the R-EEV at home and abroad, of which energy utilization is very low for the energy conversion of engine power to electric energy and electric energy to motor power. Moreover, compared with four wheel drive, most of the R-EEV is two wheel drive, of which the ground adhesion utilization is so low that the vehicle cannot adapt to some special road condition well and realize the recovery of all-wheel braking energy. Based on the analysis above, a research on a new powertrain of R-EEV was conducted in this study to improve the dynamic performance of vehicle and enhance the adaptability of vehicle to different road conditions.

2. STRUCTURE AND OPERATION MODE ANALYSIS OF R-EEV

The structure of R-EEV proposed mainly consists of APU (including engine and integrated starter generator (ISG), which is a PMSM), power driving system (including power battery and driving motor) and transmission system (including wet multi-disc clutch, gearbox, final drive and differential), which are shown in Fig. (1). The main pure electric drive type of the R-EEV is that the driving motor drives the rear axle. The engine drives the ISG motor to transfer the power to battery pack, and the engine can also drive the front axle directly. The R-EEV can work in different modes based on different states.

2.1. Charge Depleting Mode (CD Mode)

When the state of charge (SOC) is high ($SOC > SOC_{low}$), the vehicle travels in the EV mode. The engine is turned off when the vehicle runs in CD mode, which can realize zeroemission. The power flow is shown in Fig. (2).

^{*}Address correspondence to this author at the State Key Laboratory of Mechanical Transmission, Chongqing University, Chongqing, 400044, China; Tel: 13996073282; Fax: +86-23-65106506; E-mail: hujianjun@cqu.edu.cn

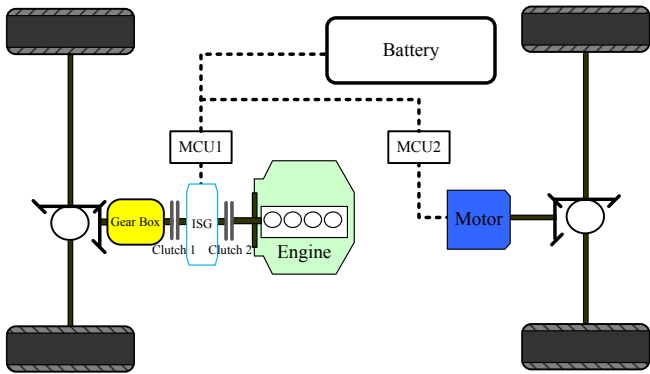

Fig. (1). Structure scheme of R-EEV powertrain.

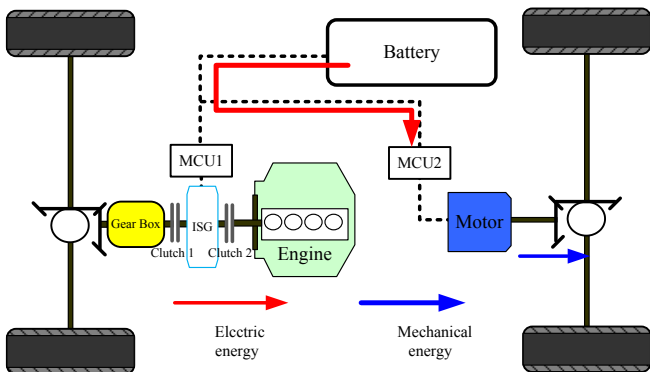

Fig. (2). Power flow in CD mode.

Moreover, when the driving wheel tends to slip on the road of small adhesion coefficient or the demand torque is larger, and the vehicle needs to be started under a large slope. The ISG operates to drive the front axle, while the driving motor goes on driving the rear axle, and the power of both are coupled by the road to realize four-wheel drive (4 WD), so that the adhesive force is fully used and the dynamic performance of vehicle is enhanced. The power flow is shown in Fig. (3).

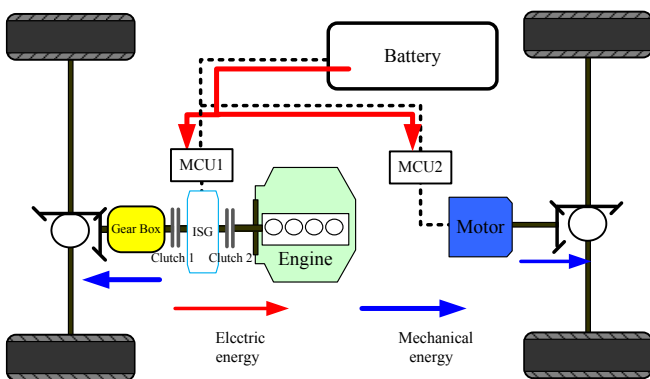

Fig. (3). Power flow in 4 WD mode.

2.2. Charge Sustaining Mode (CS Mode)

When the SOC is lower than a limit value ($SOC \leq SOC_{low}$), the vehicle runs in the range-extended mode, of which the principle is that each dynamic source works in high efficiency areas and the energy loss owing to the multilevel conversion of energy is reduced as far as possible. The range-extended mode includes series range-extended mode, engine drive mode and co-driving mode.

2.2.1. Series Range-Extended Mode

When the velocity is low, the highest velocity is less than 50 km/h in the urban driving cycle referring to the ECE cycle, and there is more acceleration and deceleration. At this moment, the demand power is small, and the engine cannot be guaranteed to operate in a high efficiency area when it drives the wheel directly, so the vehicle can be switched to the series drive mode. The power flow is shown in Fig. (4). The engine drives the ISG motor in optimal working site to generate electricity that is directly supplied to the driving motor, which drives the rear axle in the mode, while the extra electricity is stored in the battery pack.

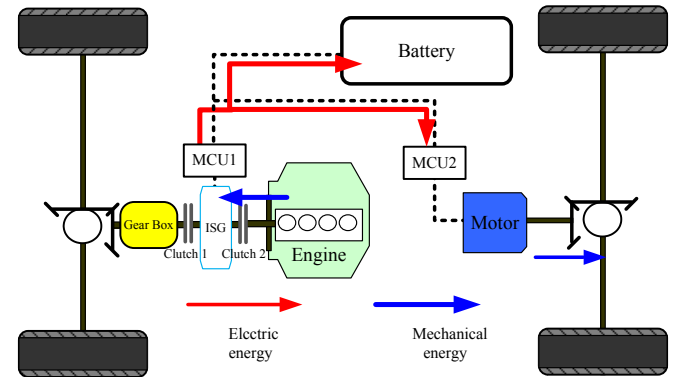

Fig. (4). Power flow in series range-extended mode.

2.2.2. Engine Drive Mode

The engine drive mode is used when the vehicle runs at a high cruising speed (the velocity is between 50 and 120 km/h referring to the ECE cycle), of which the power flow is shown in Fig. (5). The engine power is directly transferred to the front axle, and the engine operates in a high efficiency area by changing the ISG motor's working state. The power used to drive the vehicle is mainly supplied by the engine of which the extra energy is stored in the battery, and the inadequate power could be supplied by the battery to the ISG motor to meeting the power demand under the acceleration condition of vehicle.

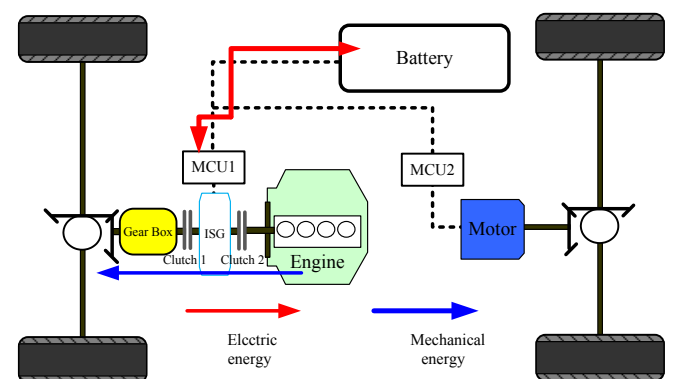

Fig. (5). Power flow in engine drive mode.

2.2.3. Co-Driving Mode

The torque demand of vehicle cannot be met by the engine separately when the extra needs to be conducted quickly at a high velocity, while the driving motor can be controlled to drive the rear wheel, and the motor torque is

coupled with engine torque by the road. The power flow is shown in Fig. (6).

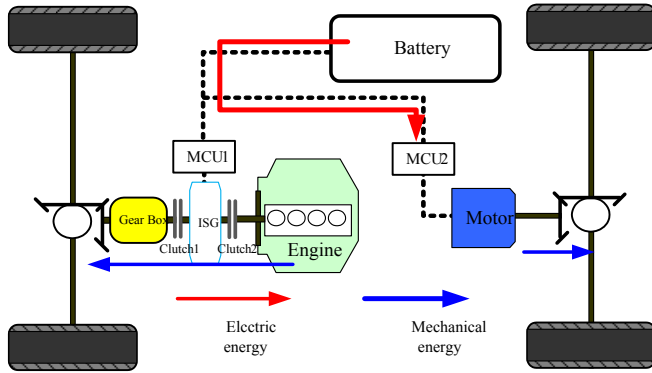

Fig. (6). Power flow in Co-drive mode.

2.3. Regenerative Brake Mode

When the vehicle is braking, if the vehicle is operated in EV mode, the ISG and the driving motor are controlled to realize the braking energy recycle by dual shaft braking. If the engine works, the wet multiple disc clutch is disengaged and then the same work as EV mode is carried out. The power flow is shown in Fig. (7).

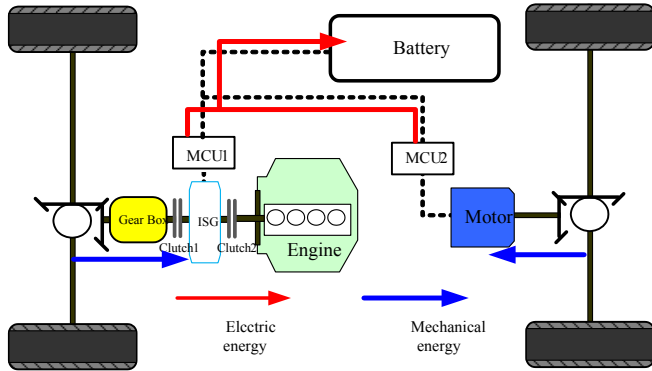

Fig. (7). Power flow in regenerative brake mode.

3. PARAMETER MATCHING OF POWERTRAIN

In this study, a traditional vehicle is selected as the prototype and it is refitted. The basic parameters and performance indexes are shown in Tables 1 and 2.

3.1. Driving Motor and Rear Axle Final Drive Ratio

3.1.1. Determination of Driving Motor Characteristic Parameters

The corresponding maximum demand power is determined by the performance indexes such as the maximum speed, the maximum grade ability and the acceleration time.

$$P_{v_{\max}} = \frac{v_{\max}}{3600\eta_T} (mgf + \frac{C_D A v_{\max}^2}{21.15}) \quad (1)$$

$$P_{t_{\max}} = \frac{v_i \left[(mgf \cos \alpha_{\max} + mg \sin \alpha_{\max} + \frac{C_D A v_i^2}{21.15}) \right]}{3600\eta_T} \quad (2)$$

$$P_{j_{\max 1}} = \frac{\frac{\delta m v_m^2}{3.6dt} [1 - (\frac{t_m - dt}{t_m})^{0.58}] + mgf v_m + \frac{C_D A}{21.15} v_m^3}{3600\eta_T} \quad (3)$$

$$P_{j_{\max 2}} = \frac{\frac{\delta m}{2t_m} (v_f^2 + v_b^2) + \frac{2}{3} mgf v_f + \frac{\rho_a C_D A}{5} v_f^3}{1000\eta_T} \quad (4)$$

Table 1. Basic Parameters of Vehicle.

Parameters	Value
Curb mass m_0/kg	1600
Efficiency of powertrain η_T	0.92
Windward area A/m^2	2.1
Final drive ratio of front axle	4.1
Tire radius r/m	0.306
Drag coefficient C_D	0.3
Coefficient of rolling resistance f	0.015

Table 2. Performance Indexes of R-EEV.

Performance index	Value
Maximum Speed v_{\max} (km/h)	Maximum ≥ 160 Cruise 80-120
Maximum grade ability i_{\max} (%)	≥ 30
0-50 km/h acceleration time t_0 (s)	≤ 6
0-100 km/h acceleration time t (s)	≤ 13
Mileage of EV mode d_1/km	≥ 80
Total mileage $(d_1 + d_2)/\text{km}$	≥ 350

The explanation of variables related is shown in the appendix I, and the following are the same. Considering that the EV mode is the main operation mode of R-EEV in the paper, the driving motor should meet the required performance index. According to the equations above, the peak power of driving motor is finally determined as 75 kW.

The rated power should not be less than the power that is required when the vehicle cruises at maximum speed (120 km/h), so it is calculated by equation (5):

$$P_{me} = (mgf + \frac{C_D A v^2}{21.15}) \frac{0.9 \cdot v_{\max}}{3600\eta_T} \quad (5)$$

The overload coefficient of motor is defined as the ratio of motor peak power and rated power, which is expressed as $\lambda = P_{m_{\max}} / P_{me}$ and valued as 2~3 generally. Referring to the specification of motor power (GB/T18488.1) combined with the calculation result of equation (5), the rated power of driving motor is determined as 30 kW.

In conclusion, a driving motor of the Dongfang Electric Company is selected, and its main parameters are shown in Table 3.

Table 3. Parameters of Driving Motor.

Parameters	Value
Peak power (kW)	75
Rated power (kW)	30
Peak torque (N·m)	200
Rated torque (N·m)	93
Maximum speed (rpm)	12000
Rated speed (rpm)	3600

3.1.2. Determination of Final Drive Speed Ratio

As it is mentioned in paper [10], when the range of speed regulating above the rated speed is large enough ($\beta = \frac{n_{max}}{n_N} \geq 2.5$), the ratio of gearbox can be determined as constant. Considering that the speed of vehicle is less than 50 km/h when it runs in urban driving cycle, the high efficient area of driving motor is near the rated speed, and 90 percent of the maximum speed of driving motor should meet the requirement of the maximum vehicle speed. So the ratio of final drive can be calculated by equation (6):

$$i_r = 0.377 \frac{r \cdot n_N}{v_c} \tag{6}$$

The final drive speed ratio of the rear axle is determined as 7.6.

3.2. Parameters Matching of Power Battery

As mentioned above, the requirements of the electric power system for R-EEV is higher. As the main energy source, power battery should not only satisfy the dynamic performance of the R-EEV but can also recycle the braking feedback energy, and meet the design requirements of the EV mode’s endurance mileage. According to the recommended value of the EV driving motor rated voltage (288~440 V), and referring to the power source voltage specification of the GB/T18488.1, the voltage of power battery is finally determined as 384 V.

3.2.1. Power Demand

The maximum discharging power of power battery should guarantee the dynamic performance of the R-EEV.

$$P_{b,max} \geq P_a + P_{max} / \eta_m \tag{7}$$

The corresponding capacity of battery is:

$$C_p \geq \frac{1000}{kU_m} \left(\frac{P_{max}}{\eta_m} + P_a \right) \tag{8}$$

3.2.2. Energy Demand

The energy of power battery should ensure a certain mileage of EV mode. When the vehicle is operated at a constant speed of v_a , the driving mileage should reach d_1 . So the energy of power battery should meet the following equation.

$$E_b \geq \frac{mgf + C_d A v_a^2 / 21.15}{3600 \times DOD \eta_t \eta_m \eta_b (1 - \eta_a)} \times d_1 \tag{9}$$

The corresponding capacity of battery is:

$$C_E \geq \frac{mgf + C_d A v_a^2 / 21.15}{3.6 \times DOD \eta_t \eta_m \eta_b (1 - \eta_a) U_m} \times d_1 \tag{10}$$

The capacity-maximum discharge rate curve (Fig. 8) is obtained based on the equations above and relevant data.

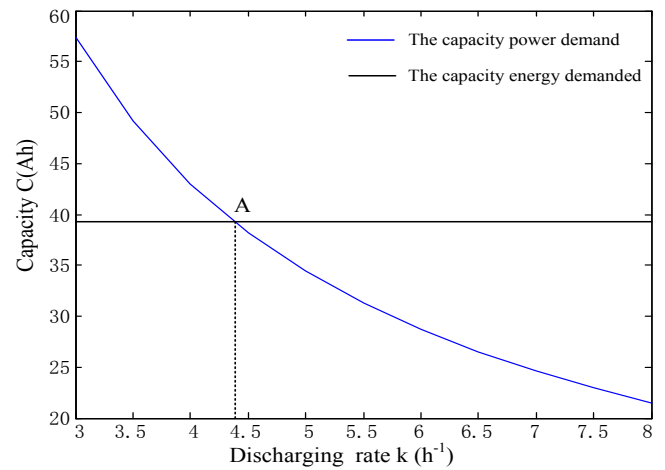

Fig. (8). Relationship between capacity and maximum discharge rate for power battery.

The capacity of the power battery can be determined by the following rule.

$$C = \min_{k=\min(k)} \{ \max[C_p(k), C_E(k)] \} \tag{11}$$

Table 4. Parameters of Battery.

Type	Lithium-Iron
Cell voltage/V	3.2
Maximum discharge current	5 C
Maximum charge current	3 C
Rated voltage /V	384
Cell number	120
SOC range	0.2~1
Capacity /Ah	40

According to the calculation result, the capacity of power battery is finally determined as 40 Ah, the maximum discharge rate is 4.5 h⁻¹, and the energy of battery pack is 15 kW·h. Table 4 shows the main parameters of lithium-iron power battery selected.

3.3. Parameter Design for APU

APU system mainly includes engine and ISG motor. According to the performance indexes shown in appendix I, the cruising speed in the range-extended mode should reach 80 km/h. Therefore, the engine power can be obtained by equation (12).

$$P_E = \frac{v_a}{3600\eta_i} (mgf + \frac{C_d A v_a^2}{21.15} + mg\lambda) \quad (12)$$

The engine power calculated by equation (12) is 18 kw. Considering that the vehicle should be equipped with a certain amount of reserve power and owe power consumed to some extent, the engine power margin is improved by 10%, and the minimum power of the engine should be 20 kw. Referring to the existing engine specifications, four-cylinder gasoline engine is selected, of which the displacement is 1 L, the maximum power is 40 kw and the maximum torque is 81 N.m. The engine universal characteristics are shown in Fig. (9).

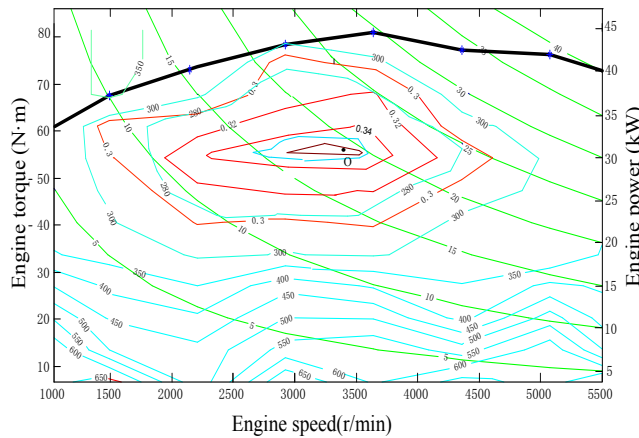

Fig. (9). Engine universal characteristics.

According to the engine universal characteristics, the capacity of fuel tank meeting the driving range d_2 can be obtained by equation (13).

$$V = \frac{Pd_2 b_e}{1000 v_e \rho} \quad (13)$$

The fuel tank capacity calculated by equation (13) is 19.3 L. Finally, the fuel tank capacity is identified as 20 L.

The ISG motor works mainly as a generator used to balance the engine power. The continuous generating region of ISG motor should be coincided with the economic region of engine to the greatest extent for reducing the engine emissions and the fuel consumption. A PMSM is selected as the ISG motor, of which the rated power is 20 kW/3400 rpm, the maximum generation power is 40 kw and the maximum speed is 6000 rpm.

3.4. Parameter Matching for Powertrain Transmission

In cruise mode, the engine should work in a high efficiency area as far as possible. As it is shown in Fig. (9), the maximum speed of engine in a high efficiency area is

4600 rpm and the minimum speed is 1500 rpm. The maximum and minimum speeds of engine should ensure that the vehicle can travel stably at 120 km/h and 25 km/h, respectively. The relationship between velocity and engine speed is the following.

$$v = 0.377rn / (i \cdot i_0) \quad (14)$$

The maximum and minimum speed ratios of transmission system calculated by equation (14) are 2.6 and 1.05, respectively. In order to ensure engine works in a high efficiency and low emission area, besides meeting the requirements of the vehicle speed, a two-speed factor is selected as $i_{g1}=2.6$, $i_{g2}=1.05$, respectively.

4. ENERGY MANAGEMENT STRATEGY

Energy management strategy is the core of vehicle control and the key to reduce the engine emissions and fuel consumption of hybrid electric vehicles. In order to improve the power performance and energy utilization of vehicle, logic threshold control strategy is adopted to control R-EEV in this study. The main logic threshold parameters used in the paper are shown in Table 5. According to the operating modes of R-EEV, the control strategies are respectively developed, of which the basic principle is the following: When SOC is high, the vehicle runs in the pure electric drive mode and the driving motor is controlled to work in a high efficiency area. When SOC is low, the vehicle runs in the extended range mode and a conversion of the energy is avoided as far as possible in the battery to reduce the energy loss. The engine is controlled to run in a high efficiency area when it works.

4.1. Control Strategy for CD Mode

The control object is mainly the motor during pure electric drive mode. R-EEV is equipped with two motors, which are ISG motor mainly for generation and driving motor mainly for driving. The control method for two motors is similar. Compared to the demand torque determined by the upper level control system with the peak torque under the current motor speed, the motor control system determines whether the motor outputs the demand torque or the peak torque, and then the motor outputs control signals L_m and the target torque T_m . Motor can be used as a generator to recycle part of the brake energy during the brake deceleration of the vehicle for its bi-directional characteristics.

$$L_m = \frac{T_r}{T_{m\max}} \text{ or } L_m = \frac{T_r}{T_{\max_gen}} \quad (15)$$

4.2. Control Strategy for CS Mode

In this phase, the control strategy of power following the engine optimization curve is used. In order to ensure that the engine can operate in a high efficiency and low emission area, the engine optimal working point O (56 Nm/3400 rpm) and high effective working area (within the brown line area where the engine efficiency is greater than 0.3) based on Engine universal characteristics are determined. Besides, the

Table 5. Logic Threshold Parameters of Energy Management Strategy.

Symbol	Parameter Description	Symbol	Parameter Description
T_r	Demand torque	T_{emax}	Maximum torque of engine
T_{mmax}	Maximum torque of motor	T_{eh}	Maximum torque of engine in high efficiency area
SOC_{min}	Minimum value of SOC	T_{eopt}	Optimal torque of engine in high efficiency area
SOC_{max}	Upper limit value of SOC	T_{el}	Minimum torque of engine in high efficiency area
SOC_{low}	Lower limit value of SOC	v_{min}	Minimum velocity of power generation
SOC_{obj}	Target value of SOC	v_{opt}	Economic velocity in high efficiency area

engine optimal torque curve (the blue dotted line), the maximum torque curve (the pink dotted line) and the minimum torque curve (the red dotted line) in high effective working area are determined. The optimized engine curve is shown in Fig. (10).

4.2.1. Series Range-Extended Mode

If the vehicle speed is low and the SOC of the battery has not yet reached its target value SOC_{obj} , such as it is operated in F point which is the low efficient working area, the vehicle enters the series range-extended mode. In this case, the engine operates at the optimal point (point O in Fig. 10), of which the engine fuel efficiency is the highest and the generator’s generating power is great. The engine drives the ISG motor to generate electricity in a higher power, which is supplied directly to the driving motor to drive the vehicle, while the rest of the electricity is stored in the power battery.

4.2.2. Engine Drive Mode

As mentioned above, the engine’s front wheel drive mode is employed when the vehicle travels at a high speed. In this case, the vehicle travels at a stable state, and the requested torque should satisfy the relationship of $T_{el} \leq T_r \leq T_{emax}$. The engine outputs the power along different working curves by detecting the value of T_r , T_{el} , T_{eopt} , T_{emax} and the relationship between SOC and SOC_{min} .

As it is shown in Fig. (10), when the torque requirement point is B, namely $T_r > T_{eh}$, and if $SOC > SOC_{min}$, then the engine works along the pink dotted line, while the insufficient power is compensated by ISG motor, i.e. $T_e = T_{eh}$ and $T_{isg} = T_r - T_e$; and if $SOC < SOC_{min}$, then the engine works along the external characteristic curve, while it drives the ISG motor to generate electricity, and the excrement energy is stored in the battery, i.e. $T_e = T_{emax}$ and $T_{isg} = T_e - T_r$. Similarly,

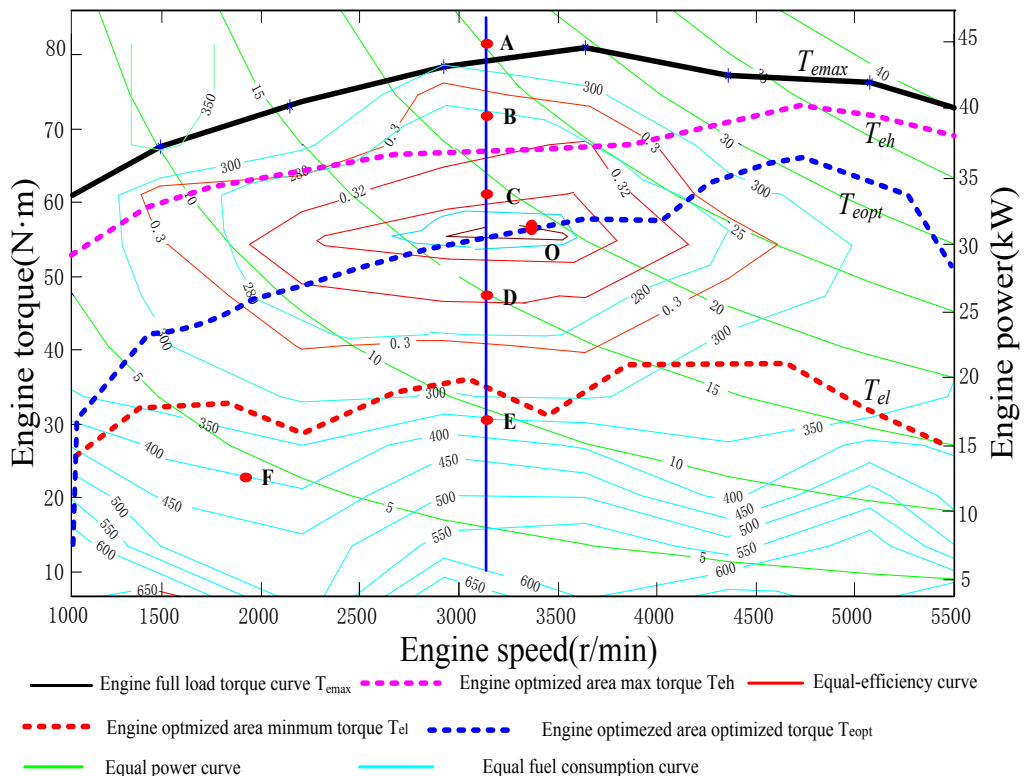

Fig. (10). Optimal curve of engine.

when the torque requirement point is C, the engine works along the optimal torque curve of the most efficient region, *i.e.* $T_e=T_{eopt}$ and $T_{isg}=T_r-T_{eopt}$ or $T_e=T_{eh}$ and $T_{isg}=T_e-T_r$; when the torque requirement point is D or E, the engine works along the blue dotted line and drives ISG motor in a larger torque, *i.e.* $T_e=T_{eopt}$ and $T_{isg}=T_e-T_r$, and the SOC quickly returns to the target value, then the vehicle works in pure electric mode.

4.2.3. Co-Drive Mode

As mentioned above, if the requested torque is larger than the maximum torque that the engine can supply in the engine drive mode, or the requested torque is larger than the torque that the motor can supply in the pure electric drive mode (point A), then the vehicle enters four wheel drive mode. In this case, the engine power and the motor power are coupled by the ground. Considering that the adjustment of the motor torque is more convenient and the demand torque of the vehicle is larger, the strategy is proposed that the engine works along the external characteristic curve and the insufficient torque is supplied by the motor, *i.e.* $T_e=T_{emax}$ and $T_m=T_r-T_e$.

4.3. Control Strategy for regenerative Brake Mode

The braking mode of hybrid vehicle can be divided into regenerative braking, union braking and mechanical braking according to the different braking intensities. As it is mentioned in the references [11] and [12], the braking is treated as emergency braking when the braking intensity satisfies $z>0.7$. When the braking is not emergency braking and the requested braking intensity satisfies $z<z_{gen}$ (z_{gen} is the largest regenerative braking intensity that the motor can generate), the whole vehicle braking force can be supplied by the driving motor and ISG. As the braking intensity is increasing, the braking must enter union braking. In the union mode, the drive motor recycles the energy with the most braking power, and the insufficient braking force is supplied by the mechanical braking. In the case of the emergency braking, the mechanical braking should be chosen for the sake of braking security.

5. SIMULATION

5.1. Dynamic Simulation

The simulation results of the R-EEV on power performance are listed in Table 6. The results show that the parameters determined by the R-EEV are reasonable, and the power performance of the R-EEV is better than the prototype vehicle.

5.2. Economic Simulation

The endurance mileage of R-EEV contains the endurance mileage of CD mode and CS mode. Simulation condition of CD mode: the initial SOC of the battery is set as 1; the vehicle travels at 40 km/h and 60 m/h, respectively. If the SOC of battery is reduced to the set threshold value SOC_{min} ,

the simulation ends. The corresponding endurance mileages are 96.43 km and 89 km, respectively.

Table 6. Simulation Results of Performance.

Parameters	Prototype Vehicle	Design Target	Simulation Results
Maximum Velocity	150 km/h	160 km/h	167 km/h
Acceleration: 0~50 km/h	-	6 s	5.1 s
Acceleration: 0-100 km/h	-	13 s	11.3 s
Grade Climbing:15 km/h	25%	30%	45%

In the engine extended-range mode, when the SOC of battery is reduced to 0.4, the engine starts. According to the requested power of vehicle and the formulated strategy, the engine drives ISG to generate electricity for driving motor and charging of battery. When the battery SOC is up to 0.55, the engine is turned off and it is switched to the pure electric mode. In the series extended-range mode, this R-EEV is set to travel at 80 km/h, while the engine runs at or near its optimal operation point. The simulation results show that the total endurance mileage of the R-EEV is up to 373 km, exceeding the expected target.

In addition, the simulation of ECE cycle on endurance mileage of the pure electric mode is carried out. The results are shown in Fig. (11). After one cycle, the battery SOC is reduced from 100% to 99.27%. According to the equation (16), the endurance mileage of vehicle is calculated as 82.19 km. The result satisfies the performance requirements.

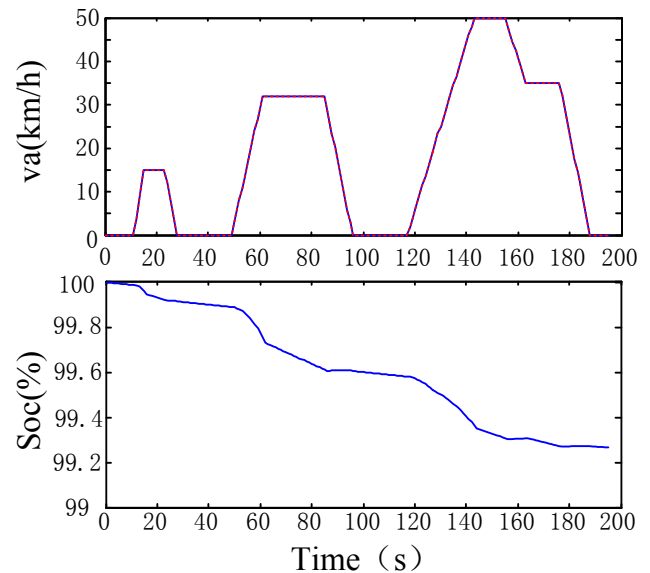

Fig. (11). Simulation results of ECE cycle condition in CD mode.

$$S = DOD \cdot S_{cyc} / \Delta SOC \tag{16}$$

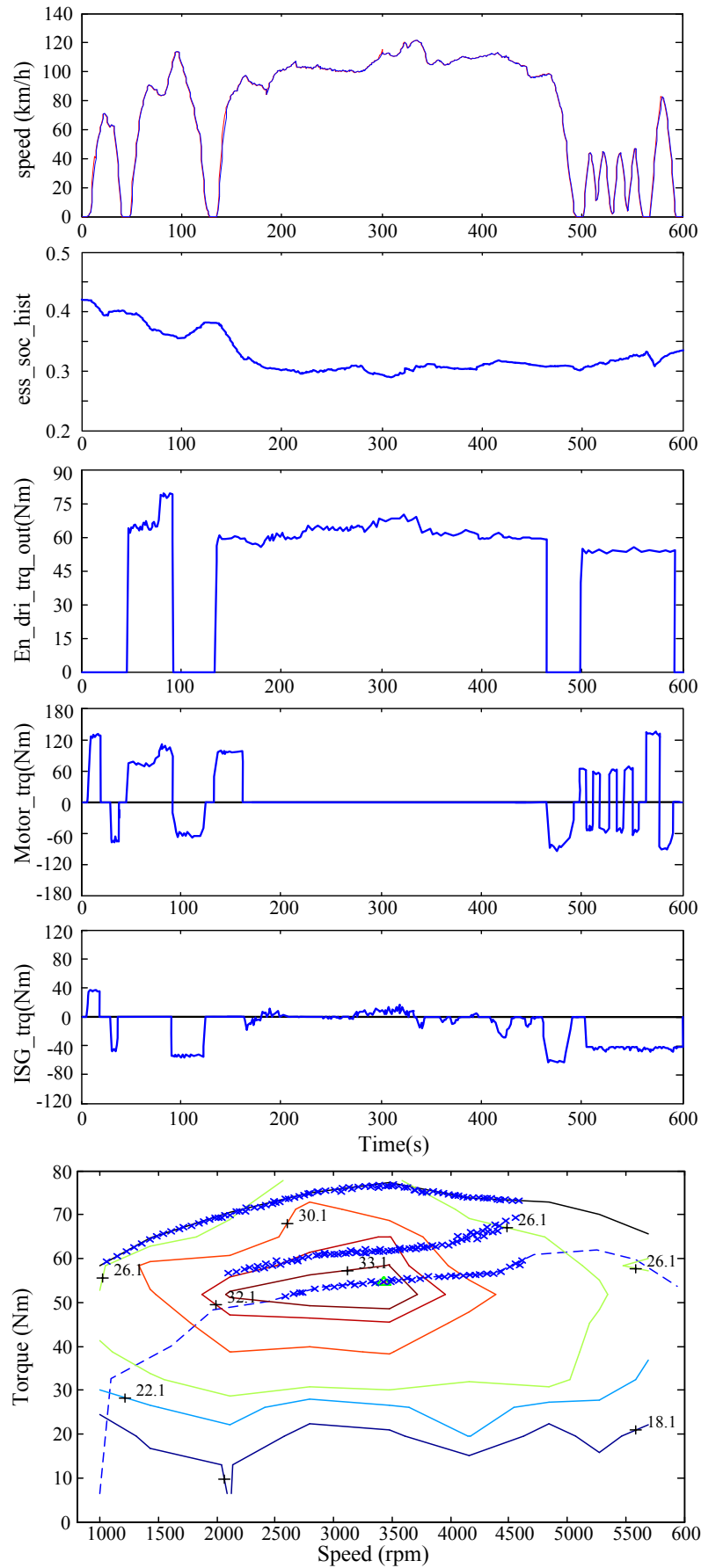

Fig. (12). Simulation results of US06 cycle condition.

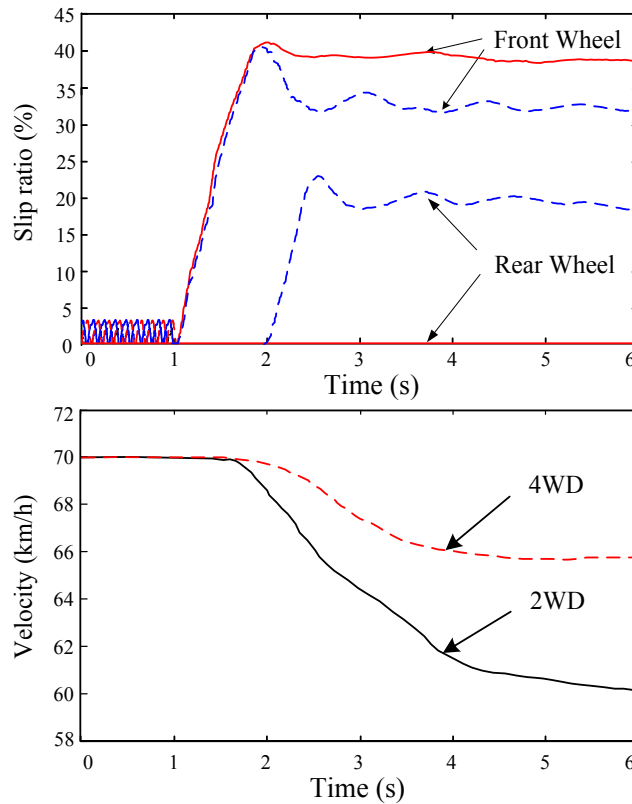

Fig. (13). Performance comparison of two-wheel drive and four-wheel drive.

5.3. Operation Simulation

The acceleration and average velocity of US06 driving cycle are higher than other driving cycle. So the simulation of US06 driving cycle is carried out to verify the strategies formulated in this study. In this simulation, the initial SOC of battery is set as 0.43. Fig. (12) depicts that the initial SOC of battery is higher than the set value 0.4, and the vehicle finishes the first acceleration process in the pure CD mode by the driving motor and ISG motor. When the battery SOC is decreased to 0.4, the vehicle switches to extended-range mode. In the second and third acceleration processes of this cycle, the vehicle needs larger drive torque, so the engine and driving motor are both involved in driving the vehicle. When the acceleration is finished, the vehicle operates at high velocity, while it works in engine drive mode. After it runs about 500 seconds, the velocity is basically at 50 km/h or less when the SOC is relatively low, so the vehicle switches to the series extended-range mode where the engine is operated in the optimal point, and the vehicle is driven by the rear axle. During the whole cycle, the ISG and drive motor can recycle braking energy to improve the energy utilization ratio of vehicle at real time, while the vehicle can switch to the appropriate operating mode based on the strategy determined to meet the power requirement of vehicle, and the control strategy is reasonable.

Fig. (13) shows the performance comparison of two wheel drive with four wheel drive on the low adhesion coefficient road. The adhesion coefficient of road is set to change from 0.8 to 0.5 in 1 second when the vehicle travels at a constant velocity. As it is shown in Fig. (13), the continuous line represents the curve of wheels slip ratio and

vehicle velocity in two-wheel drive mode, and the dotted line represents the curve of wheels slip ratio and the vehicle velocity in four-wheel drive mode. The vehicle travels onto the low adhesion coefficient road after 1 second, while the road adhesion forcedeclines, leading to the slip of driving wheels.

In two-wheel drive mode, the slip ratio of driving wheels rises sharply and exceeds the range of the optimal slip ratio, so the vehicle velocity drops quickly. At the beginning of the second second, the driving motor starts to drive the vehicle together with the engine, and the vehicle switches to co-drive mode to make full use of the road adhesion force, which can reduce the slip rate of the front wheel. At the end of the simulation, the final velocities of two-wheel drive mode and four-wheel drive mode are decreased to 62 km/h and 68 km/h from 70 km/h respectively. The result indicates that the performance is improved.

6. CONCLUSION

The operation mode of novel power transmission scheme for range-extended electric vehicle (R-EEV) was analyzed according to the different states of vehicle. Besides, the following control strategy of the engine optimization curve was proposed. Finally, the simulation of vehicle based on the Matlab/Simulink software platform was conducted on the vehicle dynamic performance and the endurance mileage, which verified the reasonability of the matched parameter. The control strategy was verified on the US06 driving cycle and the result indicated that the vehicle in accordance with the vested control strategy can switch to co-drive mode in the rapid acceleration condition, which can better meet the

power demand; besides, it verifies that the power performance of four-wheel drive is better than two-wheel drive, which is conducted on the transitioning coefficient road.

CONFLICT OF INTEREST

The authors confirm that this article content has no conflict of interest.

ACKNOWLEDGEMENTS

This research was supported by the Chongqing Natural Science Foundation (Project NO. CSTC2011BA3019). This project offered all the cost of this series of researches. The authors appreciated the support on these researches.

APPENDIX I

Symbol Meaning and Valve of parameters in Paper

Symbol	Meaning	Unit	Valve
g	Acceleration of gravity	m/s ²	9.8
v _i	Climbing velocity of vehicle	km/h	15
α _{max}	Maximum climbing angle	rad	0.245
δ	Equivalent coefficient of revolving mass changes to linear mass		1.045
v _b	Rotational speed corresponding to the rated speed of driving motor	m/s	13.89
v _r	Speed of acceleration at end time	m/s	22.22
i _r	Final drive ratio of rear axle		
i _g	Gear box ratio		
dt	Iteration steps		0.1
ρ _a	Air density	N·s ² ·m ⁻⁴	1.2258
P _{jmax}	Maximum power corresponding to Acceleration time	Kw	
P _{imax}	Maximum power corresponding to Maximum climbing grade	Kw	
P _{vmax}	Maximum power corresponding to Maximum speed	Kw	
P _a	Power consumption of vehicle accessory	Kw	
k	Maximum discharge rate of battery	h ⁻¹	
C _p	Capacity of battery determined by power	A·h	
C _E	Capacity of battery determined by	A·h	

Symbol	Meaning	Unit	Valve
	energy		
DOD	Discharge depth of battery		0.75
η _t	Transmission efficiency		0.92
η _m	Efficiency of motor and motor controller		0.95
η _b	Charge & discharge efficiency of battery		0.96
η _a	Proportional coefficient of energy consumed by accessory		0.10
v _a	Cruising speed in pure electric mode	km/h	50
v _e	Cruising speed in engine mode	km/h	80
T _{max_gen}	Maximum torque of regenerative braking	Nm	
n _N	Rated speed of driving motor	Rpm	3600
v _c	Velocity corresponding to the rated speed of driving motor	km/h	60
SOC _{low}	Lower limit valve of SOC		0.4
SOC _{min}	Minimum valve of SOC		0.2
SOC _{max}	Maximum valve of SOC		0.95
SOC _{obj}	Target valve of SOC		0.6

REFERENCES

- [1] E.D. Tate, M. Harpster, and P. Savagian, "The electrification of the automobile: from conventional hybrid, to plug-in hybrids, to extended-range electric vehicles," *SAE Technical Paper*, 2008.
- [2] X.D. Qu, Q.N. Wang, and Y.B. Yu, "A study on the control strategy for APU in a extended-range EV," *Automotive Engineering*, vol. 35, no. 9, pp. 763-768, 2013.
- [3] S. Zhou, J.G. Niu, F. Chen, and F. Pei, "A study on powertrain design and simulation for range-extended electric vehicle," *Automotive Engineering*, vol. 33, no. 11, pp. 925-927, 2011.
- [4] H. Yu, "A study on powertrain simulation of range-extended EV based on cruise software," *Electrical Engineering Technology*, vol. 39, no. 8, pp. 28-39, 2010.
- [5] S. Varnhagen, A. Same, J. Remillard, and J. W. Park, "A numerical investigation on the efficiency of range extending systems using advanced vehicle simulator," *Journal of Power Sources*, vol. 196, no. 2011, pp. 3360-3370, 2011.
- [6] G.L. Plett, "Extended kalman filtering for battery management systems of LiPB-based HEV battery packs Part 2. modeling and identification," *Journal of Power Sources*, vol. 134, no. 2004, pp. 262-276, 2004.
- [7] M. Doude, and G. M. Molen, "Design methodology for a range extended PHEV," *Vehicle Power and Propulsion Conference, Dearborn*, IEEE Xplore: USA, pp. 817-819, 2009.
- [8] Y. Gao and M. Ehsani, "Design and control methodology of plug-in hybrid electric vehicles," *Vehicle Power and Propulsion Conference*, IEEE Xplore: Harbin, China, pp. 1-6, 2009.
- [9] E.J. Schacht, B. Bezaire, B.Cooly, K. Bayar, and J.W. Kruckenberg, "Addressing drivability in an extended range electric

- vehicle running an equivalent consumption minimization strategy,” *SAE Technical Paper*, 2011-01-0911, 2011.
- [10] J.F. Zhu, and F. Gao, “Matching of motor and powertrain parameters of electric vehicle,” *Journal of South China University of Technology (Natural Science Edition)*, vol. 34, no. 3, pp. 33-36, 2006.
- [11] M. Wang, Z.C. Sun, etc, “Braking energy recovery system for electric vehicle,” *Transactions of the Chinese Society for Agricultural Machinery*, vol. 43, no. 2, pp. 6-10, 2012.
- [12] H.L. Liu, X.P. Dong, and B Zhang, “On regenerative braking control strategy for electric vehicle,” *Journal of Hefei University of Technology*, vol. 35, no. 11, pp. 1484-1487, 2012.

Received: December 8, 2014

Revised: December 15, 2014

Accepted: December 16, 2014

© Hu *et al.*; Licensee *Bentham Open*.

This is an open access article licensed under the terms of the Creative Commons Attribution Non-Commercial License (<http://creativecommons.org/licenses/by-nc/4.0/>) which permits unrestricted, non-commercial use, distribution and reproduction in any medium, provided the work is properly cited.